

4

3

2

1

Table 1:

Item No.	Qty	Part Number	Description
1	2	000923-01	TABLE SIDE 48E
2	4	000919-01	TABLE LEG 6E
3	4	000770	TABLE GUSSET
4	2	See Table 2	TABLE SUPPORT UPPER
5	2	See Table 2	TABLE SUPPORT LOWER
6	2	See Table 2	TABLE SUPPORT CROSS
7	4	002926	LEVELER
8	4	000160-01	NUT HEX 5/ 8-11 Z5
9	66	002498	T-nut 5/ 16-18
10	50	000529	HCS 5/ 16-18 X 3/ 4 Z5
11	50	000848	Washer Flat 5/ 16 Z USS
12	42	004487	Washer Schnorr 5/ 16
13	26	001956-01	HCS 1/ 2-13 X 1 1/ 2 Z5
14	26	000440-01	NUT HEX 1/ 2-13 Z
15	50	000029-01	WASHER FLAT 1/ 2 USS Z
16	26	000588	WASHER LOCK 1/ 2 Z
17	8	001539-01	TABLE SIDE END CAP

NOTE:
Deck overhang should be: 1.75"
(or 2.75" for Automatic Tool Changer spindles)

Table Home
(0,0)

6.750
DECK
ONLY

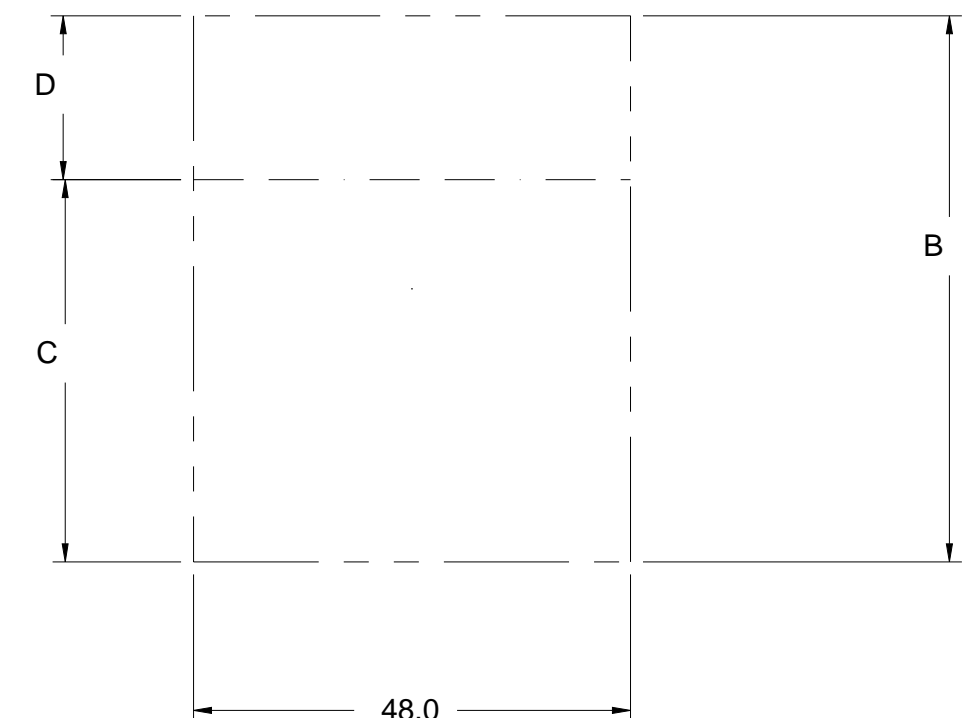
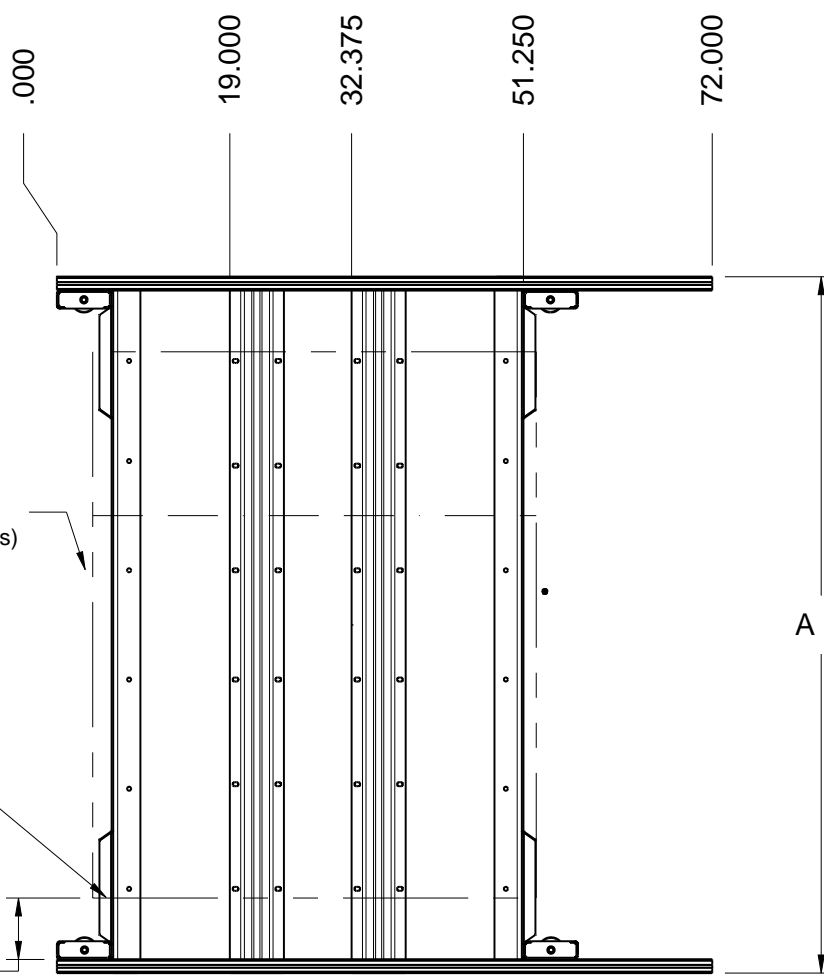

VIEW A
SEE NOTE 2

Table 2: Deck support parts and deck dimensions

Table Size	Table P/N	Dimension				Part Number		
		A	B	C	D	4	5	6
48-32-8S	10697-01	48.5"	32"	32"		002332-01	002333-01	003090-01
48-48-8S	10630-01	64.5"	48"	48"		000915-01	000921-01	000926-01
48-60-8S	10631-01	76.5"	60"	42"	18"	001486-01	001487-01	001485-01
48-72-8S	10696-01	88.5"	72"	48"	24"	001881-01	001882-01	001880-01

Table 3: Deck hardware quantity

Table Size	Bolt Carriage 3/8-16 X 1 1/2	Nut Hex 3/8 Z	Washer Flat 3/8 USS Z	Washer Lock 3/8 Z
	000953-01	000452-01	000444-01	000092-01
48-32-8S	24	24	24	24
48-48-8S	30	30	30	30
48-60-8S	36	36	36	36
48-72-8S	40	40	40	40

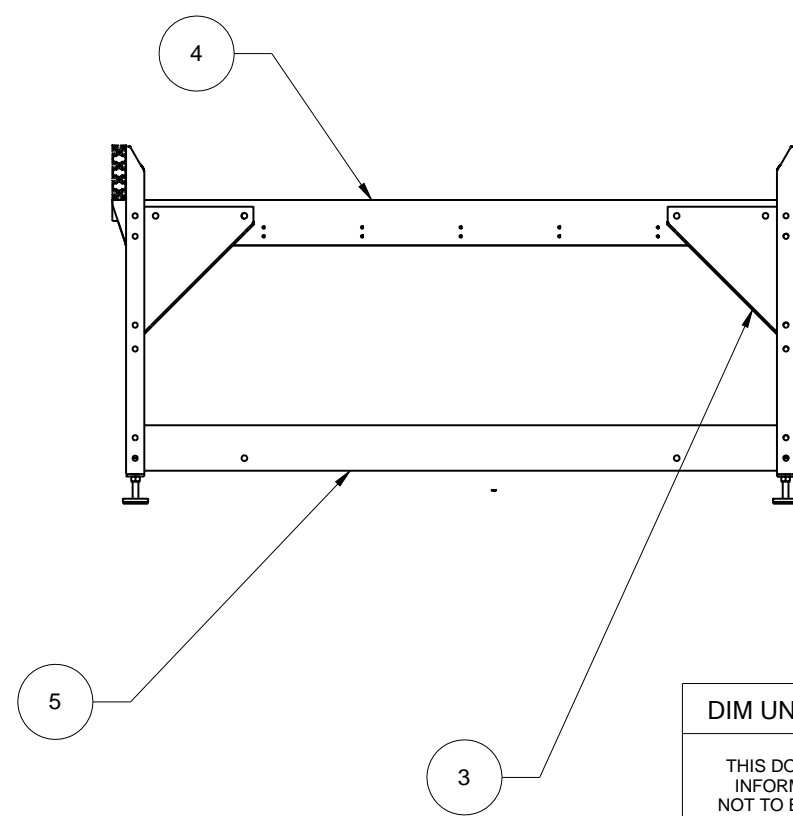
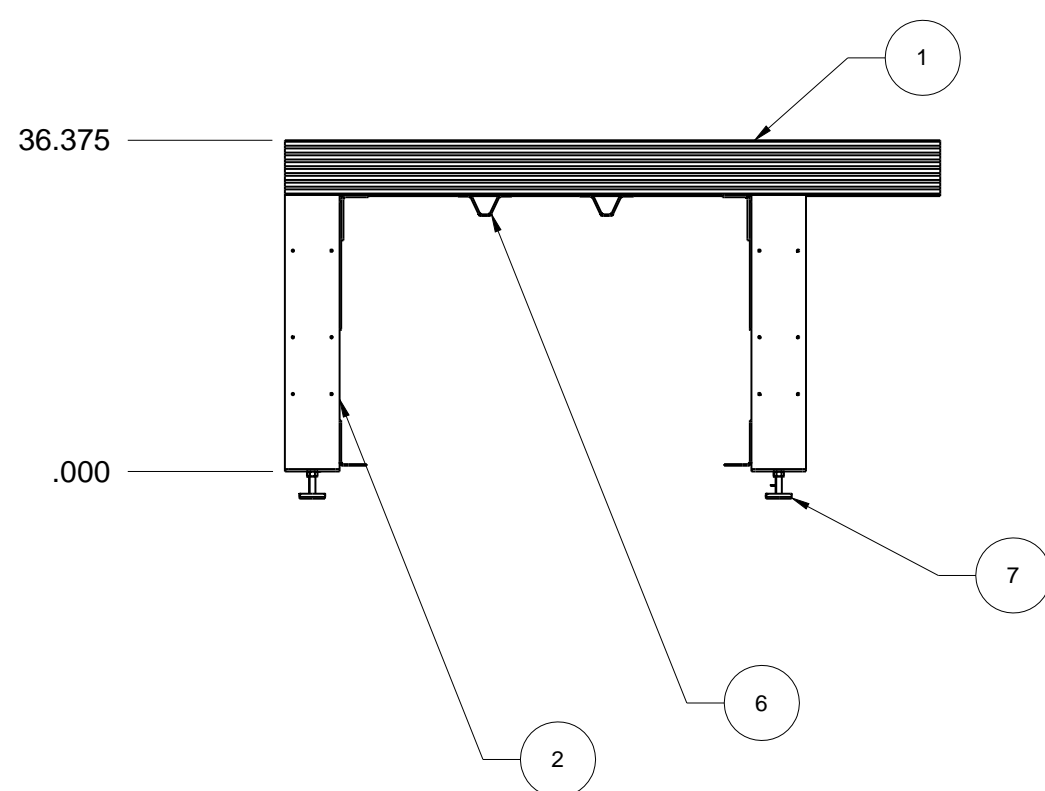

NOTES:
1. ALL DIMENSIONS ARE IN INCHES.
2. RECOMMENDED SIZE AND ORIENTATION OF DECK MATERIAL.

DIM UNITS: IN SCALE: NONE

THIS DOCUMENT CONTAINS CONFIDENTIAL INFORMATION OF SHOPBOT TOOLS. IT IS NOT TO BE REPRODUCED BY ANY MEANS OR USED TO FURNISH INFORMATION TO OTHERS WITHOUT THE EXPRESS CONSENT TO THE OWNER. THE INFORMATION SHALL BE USED BY RECIPIENTS ONLY AS EXPRESSLY APPROVED BY OWNER AND THIS DOCUMENT SHALL BE RETURNED TO OWNER UPON REQUEST. ©2008, SHOPBOT TOOLS, INC., ALL RIGHTS RESERVED

ShopBot
Durham, North Carolina

TABLE 48 8S

DRAWN KWP	DATE 5/9/11	CHECKED	APPROVED
SIZE C	DRAWING NUMBER SBG00382		REV 3
PART NUMBER SBG00382		SHEET 1 OF 1	

REV	CHG NOTICE	DATE	BY	REVISION DESCRIPTION
3	ECO 417	4/17/2017	DJP	Updated Leg and Table Position for PRS4

4

3

2

1